

# The General Radio Experimenter

VOL. IV, No. 1

JUNE, 1929

## PRODUCTION TESTING OF AUDIO-FREQUENCY AMPLIFIERS

By ARTHUR E. THIESSEN

**H**OWEVER much engineering development the manufacturer of an audio-frequency amplifier expends on its design, there remains the problem of comparing the performance of the quantity-produced unit with that of the laboratory model. Without rigorous inspection some defective units are likely to reach the user, which makes necessary expensive replacements and breeds ruinous ill will.

Some manufacturers check the component parts before assembly and follow this with a supplementary "try-it-and-see-if-it-works" test. This, however, is only partially satisfactory because errors in assembly may still creep in and because any kind of a trial inspection requires highly-competent, specially-trained inspectors if the tests are to mean anything. Even then, it is doubtful whether any listening test can be relied upon to detect small abnormalities in the performance of a high-quality amplifier under production conditions.

When preparing to manufacture their new radio receivers, the Victor Talking Machine Company realized the importance of thorough inspection and the limitations of the usual methods. They asked the General

Radio Company to build suitable test equipment, and the engineering departments of the two organizations collaborated on the design of the audio-frequency amplifier test set that is described here. It makes possible a speedy and accurate test and is capable of operation by an inspector with no special training.

The most important characteristics of an amplifier's performance are its ability to show the required amount of gain or amplification over the desired frequency range and to deliver the required amount of power without overloading. It was decided that the test of the Victor Company's amplifiers should include an accurate measurement of both these quantities.

The method chosen for making the test for gain is based upon one sometimes used for making measurements in the laboratory. Figure 1 shows it in schematic form. An oscillator operating at the test frequency supplies energy through a calibrated attenuation network to the amplifier, in the output circuit of which is connected a suitable load and a meter for measuring the voltage drop across it. The network is adjusted until the voltage across the load is equal to that measured across

the input terminals of the network. Then, if all the terminal impedances between units in the circuit have been properly matched,\* the gain of the amplifier is equal to the attenuation or loss in the network. The complete gain-frequency characteristic is obtained by repeating this measurement at as many test frequencies as necessary.

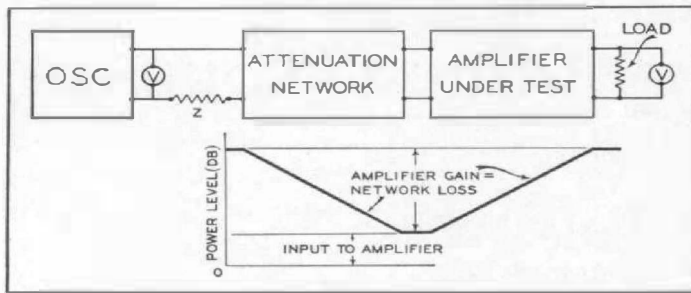

FIGURE 1. Outline chart and power level diagram for the gain-measuring method used in the amplifier test set. All impedances are assumed to be matched

The overload-level test is also based upon a laboratory method for determining where further increases in the input of the amplifier fail to produce proportional increases in the power output. The overload level is the ratio (expressed in decibels) of this power output to the standard reference level or normal test output† of 50 milliwatts.

The audio test panels as constructed are shown in the schematic diagram of Figure 2. A Hartley oscillator delivers voltages at each of five selected frequencies (40, 100, 400, 2500, and 6500 cycles) covering the audio-frequency band. At each of these fre-

\* This requirement makes necessary the impedance  $Z$ . If the oscillator output voltage be maintained constant as shown by the voltmeter, the network behaves as though it were working out of a power source of constant internal electromotive force and internal impedance  $Z$ . See K. S. Johnson, *Transmission Circuits for Telephonic Communication* (New York: D. Van Nostrand Co., 1925), Chapter VIII, in particular.

† I. R. E. Standard. See *Year Book of the Institute of Radio Engineers* (New York, 1929), p. 107.

quencies the voltage of the oscillator is made the same by an adjustment of the respective feedback resistances.

From the standpoint of the inspector using the test set, it is desirable that the power output of the amplifier be constant at every one of the test frequencies, in spite of the fact that the amplifier gain is different for each one. Then it is only necessary for him to note whether or not the load voltmeter deviates from a fixed value marked upon the dial in order to tell whether or not the amplifier is up to standard. This is accomplished by inserting enough attenuation ahead of the amplifier to make the output the same at each frequency. This is the function of the compensation network shown in Figure 2. Both the frequency change and the throwing in of the proper compensation network are made by means of the large hand-wheel at the left of the panel shown in Figure 3.

An alternating-current-operated vacuum-tube voltmeter is used to measure the voltage across the load and to check occasionally the output voltage of the oscillator. It is sufficiently sensitive to indicate deviations of amplifier gain from normal by as little as one or two decibels. The voltmeter is the one in the center of the panel.

The input and output networks for making the overload-level test are controlled by the other hand-wheel. As its pointer is moved from left to right in ten successive steps, an attenuation of two decibels per step is inserted ahead of the amplifier, and, simultaneously, the same amount is removed from the output circuit. So long as the amplifier is operating below its overload level, the reading of the voltmeter remains fixed, but, when overload occurs, further increases of input fail to produce proportional increases in the output power. Thus, the overload level is indicated when the

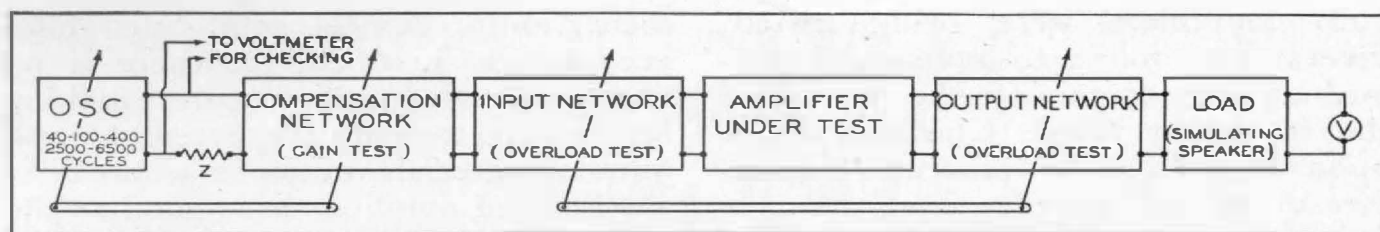

FIGURE 2. Schematic diagram of the test panel for making rapid measurements of gain and overload level in amplifiers

output voltage begins to drop off as the test switch is advanced.

In testing an amplifier under working conditions, it is merely necessary to connect it to the test panel by means of a set of flexible leads. With the overload-level switch set at zero the gain test is made at each of the five test frequencies, and, if the reading of the output voltmeter does not deviate from standard by more than a specified tolerance, the amplifier has been shown to have a gain-frequency characteristic like that of the laboratory model. The next step is to set the frequency control at some point — 400 cycles, for example — and to advance the overload-level switch until the output voltage begins to fall off. The setting of the switch where this occurs indicates in decibels the overload level of the amplifier referred to the reference level.

At the extreme lower right of the panel, next to the toggle switch for controlling the power supply to the test set, may be seen two key switches. One of these throws the voltmeter from the amplifier output circuit to the output of the oscillator for checking its voltage.

Since the audio amplifier is intended for use in conjunction with a phonograph pickup (low impedance) as well as the detector tube of the radio receiver, its input circuit has a low- as well as a high-impedance winding. Gain and overload-level tests are made for each winding, and the second key switch makes the necessary internal changes in the test panel.

By means of this extremely rapid check practically all of the possible errors in construction will have been shown up. When the first production-

FIGURE 3. The audio-amplifier test set as built by the General Radio Company for the Victor Talking Machine Company

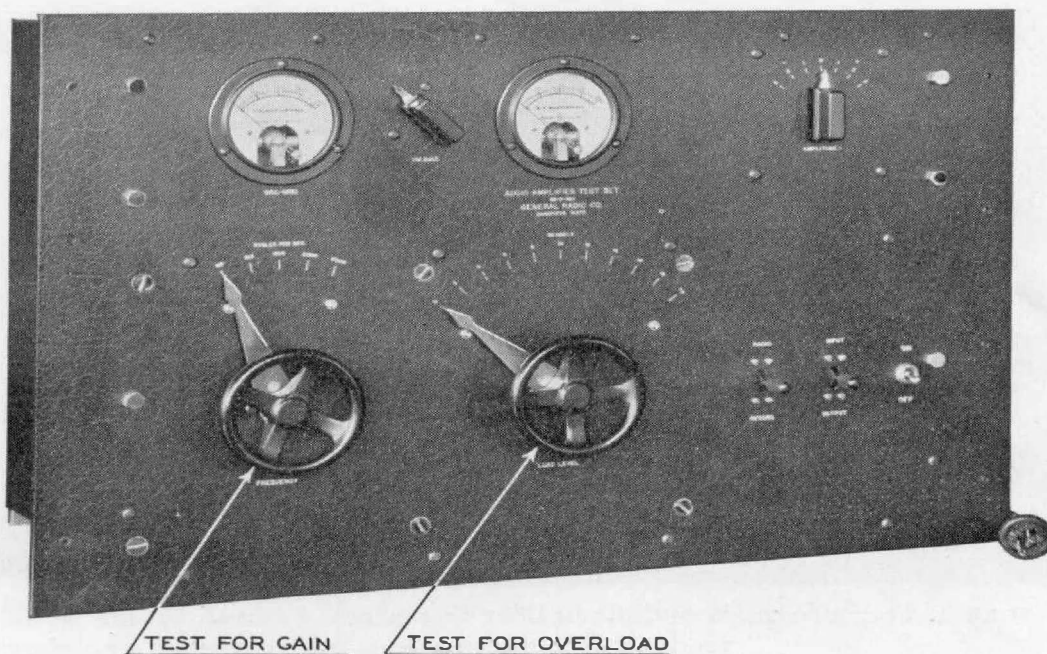

built amplifiers were being tested, several were found to have a sub-normal amount of gain in the middle of the frequency band. Checking them upon the elaborate laboratory gain-measuring set proved that the test panels were operating correctly, but the trouble could not be traced to any fault in the amplifier until it was discovered that the lower-grade wax used for impregnating the power transformers had been inadvertently used in the inter-stage coupling transformers. It is highly probable that a simple listening test would not have found the trouble, yet the accident is one that could happen in any assembly plant.

By the use of the General Radio Company's test panels, the Victor Company makes its production with great speed and accuracy and with a consequently low unit cost of test. The average time necessary for a complete check is about one minute, and the amount of deviation from standard is held to a tolerance of one and one-half decibels. This test compares favorably in accuracy with the more elaborate laboratory measurements requiring considerably more time, equip-

ment, and technical skill. Such high accuracy is justified, for there is no excuse for the manufacturer making heavy investments in research and quality materials unless he is sure that the finished amplifier is as good as the approved laboratory model.

In addition to the check upon the completed amplifier, all of the component raw materials are tested before assembly. All input, interstage, and output coupling transformers are inserted in amplifiers of known excellence which are then tested on the test panel. If the amplifier shows normal performance, the transformers are shown to be satisfactory.

Ten of these amplifier test panels have been built for the Victor Company and five more are now in process.

The flexibility of the test set makes it adaptable for use with almost any audio-frequency amplifier, and it may be readily altered to take care of such changes in the design of the amplifier that may be made after production has begun. The method of working out the problem is general enough to show definitely that laboratory methods can successfully be applied to production tests.

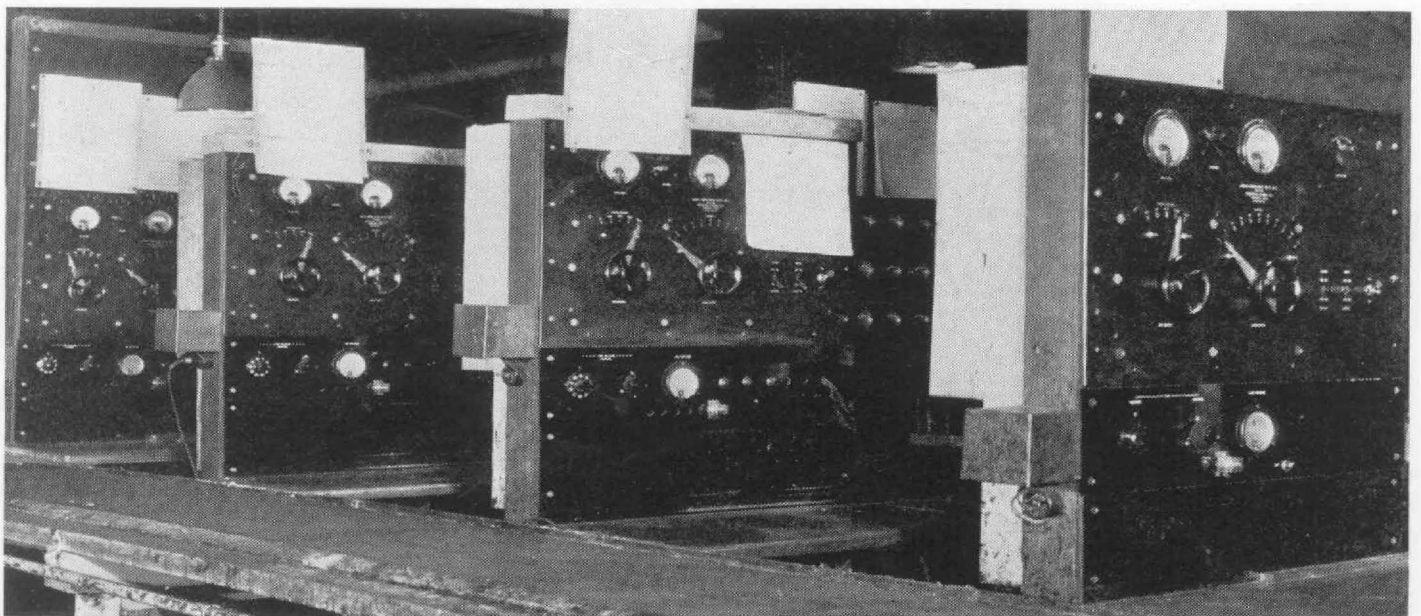

FIGURE 4. Four of the six audio-amplifier test panels as used by the Victor Company for making production inspection tests on completed amplifiers

# NEW TESTING INSTRUMENTS FOR THE RADIO SERVICE LABORATORY

**I**N its exhibit at the R. M. A. Trade Show in Chicago early this month and in its advertising, the General Radio Company announced that several new items of test equipment for the radio service man were being developed. So many requests for information have been received that the following descriptions are being published, even though all three instruments are still in our laboratory undergoing their final tests. These specifications must, therefore, be regarded as preliminary and subject to revision before they are formally announced.

## TYPE 486 Output Meter

This instrument will be suitable for measuring the power output of a radio receiving set at any frequency in the audio-frequency band. It will consist of a 4000-ohm resistor for replacing the speaker or output transformer and an alternating-current voltmeter of the copper-oxide-rectifier type connected across it. The voltmeter has a full-scale reading of 3 volts, but multipliers placed in circuit by a switch make it possible to increase this range by 5, 20, and 50 times to a maximum of 150 volts. The TYPE 486 Output Meter will, therefore, be capable of measuring any power output up to 5.6 watts.

Delivery upon this instrument has been set for August 1. A full description is scheduled to appear in the July issue of the *Experimenter*. The price will be \$34.00 and the code word MALAY.

## TYPE 360 175 & 180 K.C. Test Oscillator

This instrument will replace the TYPE 320 180 K.C. Test Oscillator built by the General Radio Company for aligning condensers and for neutral-

izing and making continuity tests upon superheterodyne receivers having an intermediate-frequency of 180 kilocycles. The new one will consist of a modulated vacuum-tube oscillator capable of furnishing test signals at any frequency in the broadcast band as well as at the two high frequencies mentioned in its formal title.

It will be operated by batteries. An output meter of either the copper-oxide-rectifier type or the thermogalvanometer type will be mounted in the cabinet which will be approximately 10 $\frac{3}{4}$  by 10 $\frac{3}{4}$  by 7 inches.

## TYPE 404 Service Test Oscillator

This instrument is intended for the usual aligning of tuning condensers, neutralizing, and the making of continuity tests on radio receivers, but it will, in addition, make it possible for the dealer and the service man to make tests for receiver sensitivity.

It will have a modulated vacuum-tube oscillator capable of being operated at any frequency in the broadcast band. Across the output of this oscillator will be connected an attenuator or voltage divider so that known radio-frequency voltages may be impressed upon the input circuit of the receiver. By measuring output power (with the TYPE 486 Output Meter, for example) an approximate frequency-response curve may be obtained for the receiver.

It will be operated from the 110-volt alternating-current power supply. The cabinet will be approximately 10 $\frac{3}{4}$  by 10 $\frac{3}{4}$  by 7 inches.

No estimates of price or of delivery date on either oscillator can be made at the present time. Full information will appear in the *Experimenter* as soon as it is ready.

# DIRECT-CURRENT AMPLIFIER DESIGN

By CHARLES E. WORTHEN

**A** MEANS of magnifying the intensity of slowly-varying voltage pulses is often needed in experimental work. Amplifiers for television and for vacuum-tube voltmeters must respond to low frequencies and to direct current (zero cycles per second), but the usual types of audio-frequency amplifiers are not suitable because they do not operate effectively at frequencies much below 25 cycles per second.

Although there is nothing particularly new about a direct-current amplifier, we are describing here one of two stages built by the General Radio Company, because it presents an interesting example of amplifier design (see Figure 1). It was to be used in conjunction with an electrocardiograph, an instrument used by the medical profession in the study of heart action. During the heart beat potential differences of the order of a few millivolts appear between active and inactive heart muscle. These voltages are applied to the input of an amplifier and

passed on to an Einthoven (string-type) galvanometer for recording.

From the schematic diagram of Figure 2 it may be seen that this amplifier is of the resistance-coupled type in which the grids of the vacuum tubes are held at the proper operating potential by means of batteries instead of the usual blocking condensers and grid leaks. With no signal voltage applied across the input terminals, each tube is operating at a suitable point on the linear portion of its grid-voltage plate-current characteristic. A voltage applied to the grid of the first tube causes a change in its plate current which, in turn, produces a change in the voltage drop across the plate resistor  $R_1$  and alters the grid bias of the second tube. This produces a change in the plate current of the second tube and a change in the voltage across the output circuit. A scheme for balancing out the steady plate current of the second tube in the output circuit is provided. It will be described later.

If the proper operating points have

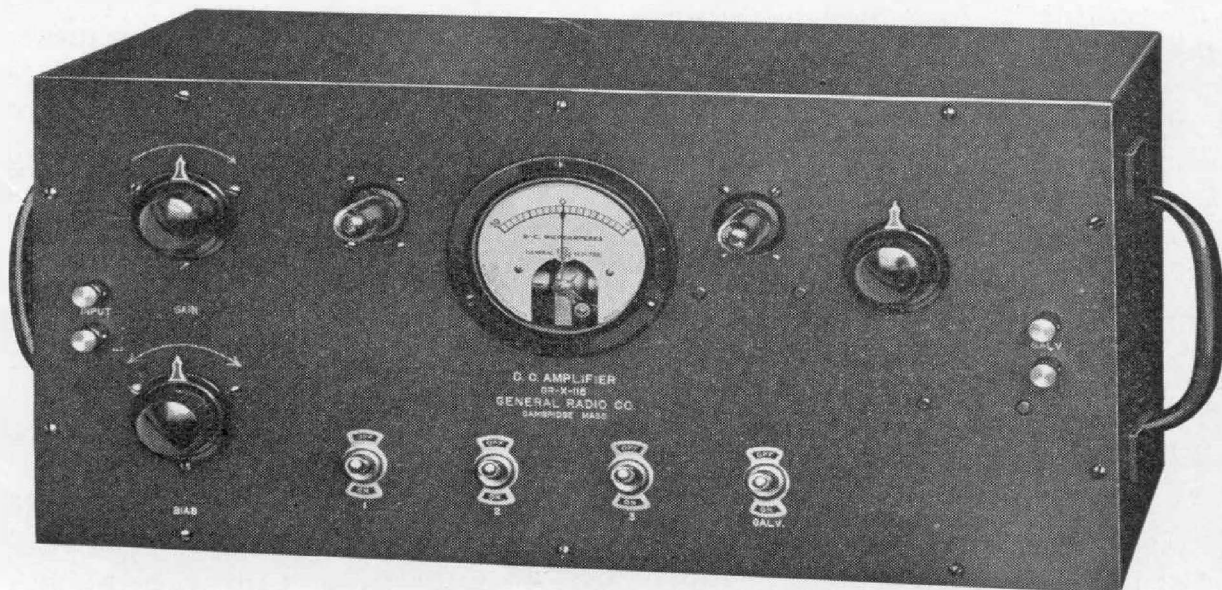

FIGURE 1. A two-stage direct-current amplifier, a piece of special equipment built by the General Radio Company

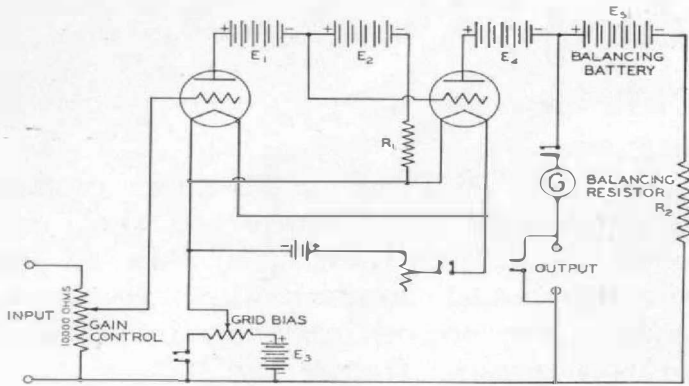

FIGURE 2. Circuit diagram of the direct-current amplifier of FIGURE 1

been chosen, the change in plate voltage in each tube is greater than the grid voltage change. The amount of this amplification depends upon the value of plate resistors used as well as upon the operating points chosen. The over-all amplification will, in general, be less than the product of the amplification factors of the tubes. It should also be noticed that successive voltage changes are out of phase by 180 degrees. If the change on the grid of the first tube be in a positive direction, that on the second grid is in the negative direction. This fact might be an important consideration when deciding whether an amplifier should consist of an even or an odd number of stages.

The considerations involved in the design of a direct-current amplifier can be better understood by means of the graphic analysis of Figure 3. This analysis holds only for small values of applied voltage on tubes biased to operate on the linear portions of their characteristics. The grid-voltage-plate-current characteristics are plotted as shown, that of the second tube being to the right of and above the first. If the two operating points are *A* and *C*, lines drawn from these points perpendicular to the axes will intersect at *B*.

For a given value of  $R_1$ , the drop across it is  $I_{p0}R_1$ . Through *B*, then, draw a line intersecting the voltage axis at an angle equal to  $\tan^{-1} \frac{1}{R_1}$ .

From the geometry of the figure it is then evident that the distance subtended by this line on the voltage axis is equal to  $I_{p0}R_1$ . Since this gives the grid of the second tube too large a negative bias, the battery  $E_2$  supplies enough positive bias to bring the grid to the selected operating point. Referring again to the diagram, it may be seen that  $E_2 - I_{p0}R_1 = E_{g2}$ . This graphic analysis makes it possible to study the effect of changing the values of the batteries and of  $R_1$ . It is extremely useful in designing direct-current amplifiers.

In order that no current shall flow in the output circuit except when a voltage is applied to the input, the steady plate current in the second tube

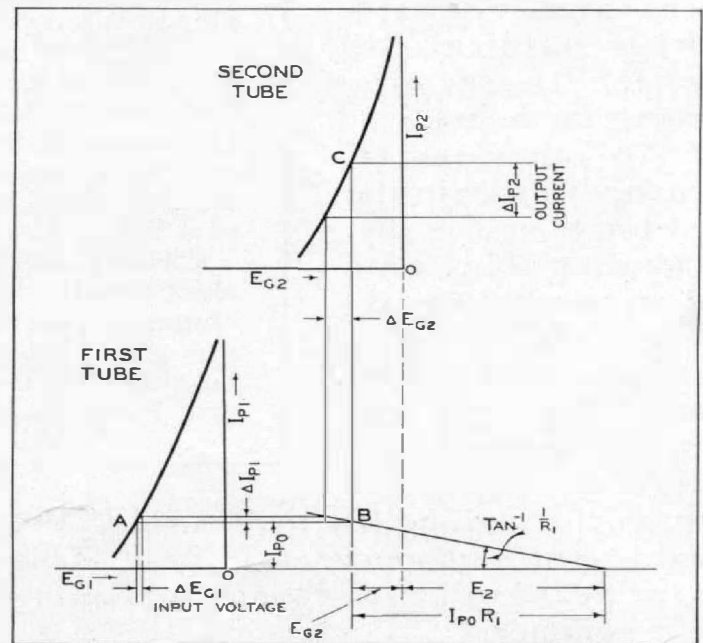

FIGURE 3. Graphic analysis for a two-stage direct-current amplifier

is balanced out. Referring to Figure 2, the balancing resistor  $R_2$  is made equal to the plate resistance of the second tube, and the balancing battery  $E_5$  is made equal to the battery  $E_4$ . Under these conditions, no voltage appears across the output circuit unless one is applied to the input. A zero-center galvanometer is provided in the instrument for indicating the balance condition.

## MISCELLANY

By THE EDITOR

**W**ITH this number, the first of Volume IV, the *General Radio Experimenter* appears in a new format. The new page is only one-half as large as the old one (6 inches by 9 inches instead of 9 inches by 12 inches), but doubling the number of pages makes it possible to include as much material as before. Besides making it easier to handle, the smaller size brings the *Experimenter* more nearly into uniformity with other publications which the reader keeps for reference.

No other radical changes either in the editorial or the distribution policies are contemplated. There is no subscription fee, and we ask only that our readers express a desire to continue upon the mailing list by returning the card sent out once each year. This year's card will go out sometime during the summer.

\* \* \* \*

The following excerpts from recent issues of one of the popular magazines arouse us sufficiently to suggest that their editors encourage contributors to show more respect for the decibel: (a)

"With an input of 15 db at 30 cycles the inductor motor moves a ten-inch cone one-eighth inch." (b) "In all [of the author's] loud-speaker response curves, the sound intensity in db was plotted against frequency."

The decibel is, by definition, a measure of a ratio between two amounts of power, the number of decibels corresponding to a power ratio being given by  $db = 10 \log_{10} r$ , where  $r$  is the ratio. Obviously, specifying a power input or an intensity of sound in decibels is as devoid of meaning as the statement that the power input to a motor is 95 per cent. We admit, however, that "decibel" does sound more impressive.

It is possible, of course, to express an amount of power as so many decibels "above" or "below" a specified amount of power called the zero or reference level, but so many different reference levels are in use that it is always well to state which one is being used. Including it takes only a little more effort on the part of the author and greatly minimizes the chance of misleading the reader.

### CONTRIBUTORS

**B**OTH contributors to this issue of the *Experimenter* are members of the General Radio Company's Engineering Department:

**ARTHUR E. THIESSEN**, Bachelor of Engineering, Johns Hopkins University, 1926. 1926-1928, Bell Telephone Laboratories, Inc. 1928 to date, Engineering Department, General Radio Company.

**CHARLES E. WORTHEN**, Bachelor of Science, Massachusetts Institute of Technology, 1928. 1928 to date, Engineering Department, General Radio Company.

The *General Radio Experimenter* is published monthly to furnish useful information about the radio and electrical laboratory apparatus manufactured by the General Radio Company. It is sent without charge to interested persons. Requests should be addressed to the

**GENERAL RADIO COMPANY**  
CAMBRIDGE A, MASSACHUSETTS